

User Guide

4GE+2GE Web Smart Switch

This document applies to the 4GE+2GE Web Smart Switch. Unless otherwise specified, 4GE+2GE is used as an example in the product figure.

Packing List

When using the Switch for the first time, carefully open the packing box. The packing box should contain the following items:

- Switch *1
- User manual *1
- Power cord *1
- Feet*4

 **Note:** Precision devices are built in the device, please handle them carefully to avoid violent vibration, which may affect the performance of the device. If you find that the equipment is damaged or any parts are lost in the process of transportation, please inform us, we will give you a proper solution as soon as possible.

Chapter 1 Product Introduction

1.1 Product Overview

4GE+2GE is our independent research and development of Web Smart Switch! Provides 6*10/100/1000Mbps adaptive RJ45 ports, each supporting MDI/MDIX automatic flip and wire-speed forwarding. It is easy to use and flexibly expand home and office networks without limitation of power line layout. It is easy to manage and maintain and meets the requirements of different scenarios.

Chapter 2 Product Appearance Description

2.1 Front Panel

The front panel consists of 6*10/100/1000Mbps adaptive RJ45 ports and related indicators, as shown below:

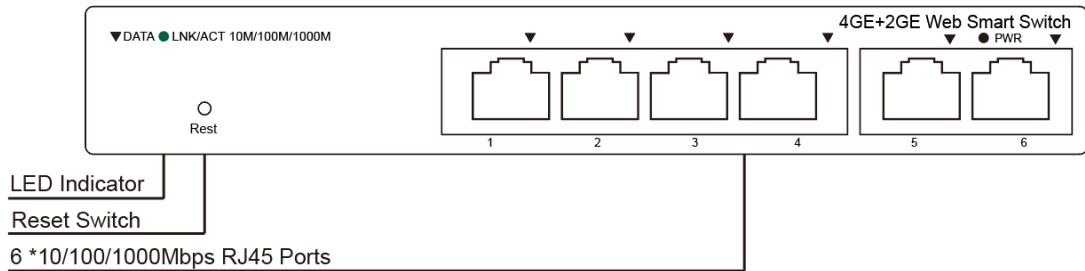

Figure 2-1 Front panel of the 4GE+2GE Switch

4GE+2GE Port description:

➤ 10/100/1000Mbps RJ45 Ports

Supports 10Mbps, 100Mbps and 1000Mbps rate adaptation, auto-MDI /MDIX, and each port has a corresponding indicator, that is, port indicators 1-6 as shown on the panel in the figure above.

➤ Reset Switch

Reset Switch is simply a Switch that can reset automatically. After long pressing for 5s, the initial state will be restored when the hand is released.

➤ LED Indicator

The LED indicator is used to indicate the different working status of the Switch, so that we can check whether the Switch is working properly in time.

2.2 LED Indicator

The LED indicators of the Switch are shown in the following table. Users can monitor the work and running status of the Switch conveniently and quickly through the following indicators:

LED	Color	Function
PWR	Orange	Off: No Power supply. Light: Indicates the Switch has power.
DATA	Green	Off: No device is connected to the corresponding port. Light: Indicates the link through that port is successfully established at 10/100/1000Mbps. Blink: Indicates that the Switch is actively sending or receiving data over that port.
LNK/ACT	Green	Off: The network is not connected Steady on: A 10/100/1000Mbps network device is connected Blinking: Data is being transferred

2.3 Rear Panel

The rear panel of a Switch shows the AC power port. The power input ranges from 100-240V AC at 50/60 Hz.

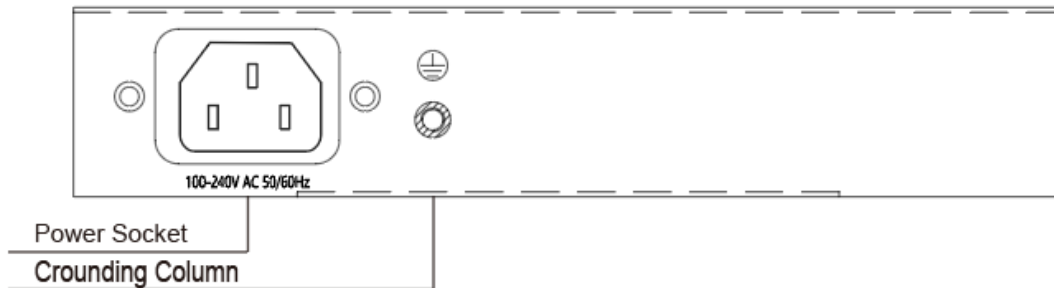

Figure 2-2 Rear panel of the 4GE+2GE Switch

AC power port

This is an AC power socket, connect the negative plug of the power cord to this interface, and connect the positive plug to the AC power supply.

Lightning protection grounding pole

It is located to the left of the power interface. Please use wire grounding to prevent lightning strike.

Chapter 3 Installation Guide

This chapter helps users correctly install and safely use Switches.

3.1 Installation Precautions

 **Precautions:** To avoid equipment damage and personal injury, observe the following precautions:

- The Switch room should be dry and ventilated, free from corrosive gases and strong electromagnetic interference.
- The humidity of the Switch equipment room should be less than 90%. Install proper devices when possible;
- The grounding of the Switch shall comply with the grounding requirements described in this manual, and shall be separately and well grounded.
- The Switch voltage should be stable to prevent abnormal operation of the Switch caused by power supply voltage mutation, fluctuation and other phenomena;
- Keep a proper distance between the Switch and other devices. Do not stack other devices with the Switch.
- The connection cable between the Switch and the distribution frame should be standardized and reasonable, and the distribution frame (box) jumper wire should be concise and clear to prevent the phenomenon of parallel lines and wires;
- To avoid the danger of electric shock, do not open the chassis without authorization; If any fault occurs, contact professional maintenance personnel.

 **Safety Tips:**

- Use a three-hole socket with safe grounding, and ensure that the PGND cable of the power socket is properly grounded.
- Ensure sufficient space for heat dissipation and ventilation of the Switch. Do not place heavy objects on the Switch.

3.2 Installation Environment

Before installation, make sure that the proper working environment is available, including power requirements, adequate space, proximity to other equipment to be connected, and other equipment in place. Please confirm the following installation requirements:

- Ensure the stability of the workbench and good grounding;
- Check whether cables and connectors required for installation are in place (less than 100m).
- The product does not provide installation components. Prepare components of the selected installation type, such as screws, nuts, and tools, to ensure reliable installation.
- Environment requirements: The operating temperature ranges from 0°C to 40°C and the relative humidity ranges from 5% to 90%.

3.3 Installation

Desktop installation

- Place the bottom of the Switch face up on a large enough stable desktop;
- Carefully position the Switch upright on the workbench;

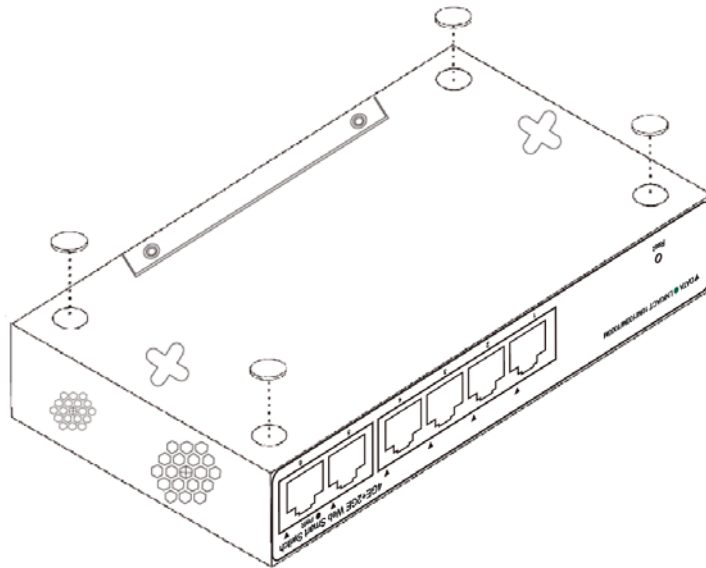

Figure 3-1 Desktop Installation Diagram

Wall mounted installation

- Install the Switch by following the steps: Fix 2 screws on the wall to align the 2 fixing holes on the Switch, as shown in the figure below, and hang the Switch smoothly on the screws.

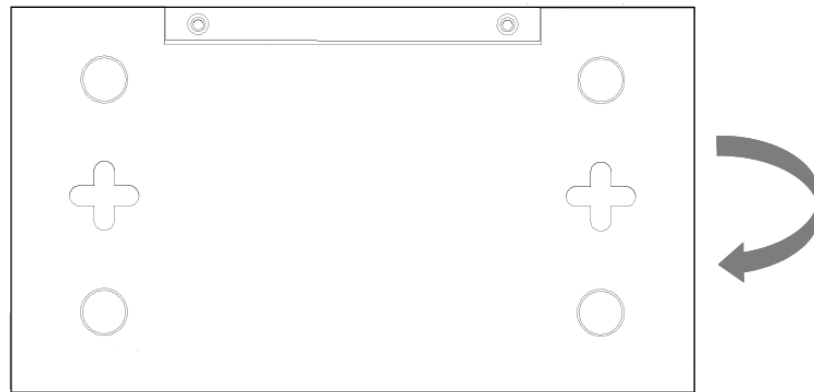

Figure 3-2 Schematic of wall-mounted installation

Enabling the Switch

Connect the power cord, plug in, and turn on the power. After the Switch is started, the Switch automatically initializes. If all port indicators are on and off, the system is successfully reset. The power LED indicator is steady on.

Note: Before powering on the device, ensure that the voltage is correct; otherwise, the device may be damaged. (Power input range: 100-240V AC 50/60Hz).

Appendix: Technical Specifications

Model	4GE+2GE Web Smart Switch
Standard	IEEE 802.3, IEEE 802.3u, IEEE 802.3ab, IEEE 802.3z, IEEE 802.3x, IEEE 802.1x, IEEE 802.1q, IEEE 802.1p, IEEE 802.1d, IEEE 802.1w, IEEE 802.3ad
Network Media(Cable)	10BASE-T: UTP category 3, 4, 5 cable(≤100m) 100BASE-TX: UTP category 5, 5e cable(≤100m) 1000BASE-T: UTP category 5e, 5 cable(≤100m)
MAC Address Table	8K, Auto-learning, Auto-aging
Jumbo Frame	9216Byte
Transfer Mode	Store-and-Forward
Switching Capacity	12Gbps
Packet Forward Speed	8.93Mpps
Dimensions (L*W*H)	168*86*32mm
Fan	Fanless
Input Voltage	AC 100-240V 50/60Hz
Power Supply	12V/1.2A
Temperature	Operating Temperature: 0°C ~ 40 °C Storage Temperature: -40 °C ~70°C
Humidity	Operating Humidity: 10% ~ 90% non-condensing Storage Humidity: 5% ~ 90% non-condensing