

# MPPT SOLAR CHARGE CONTROLLER

## M4880F/M48100F

### User Manual

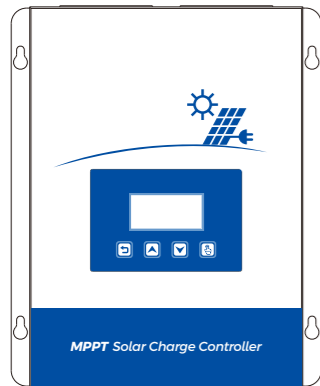

Reminder: The controllers can be installed indoor only.

#### Main Feature

- 80/100A MPPT solar charge controller.
- MPPT technology.
- 3-stage charging optimizes battery performance.
- Automatic battery voltage detection for 12V/24V/36V/48V.
- Battery OVP、Battery LDV、Solar OVP、Overcharge、Over-temperature、Reverse Polarity protection.
- Supports RS485 communication with Modbus protocol.
- Suitable for battery types such as Lead-acid AGM/GEL/Flooded & Lithium battery.
- Easy to be mounted.

#### Warning and Caution

Be aware that only qualified professionals could install these controllers. Please read all manuals before installing them.

- 1) Keep controller away from water. Don't use wet towel to wipe controller.
- 2) Keep wiring correct, don't reverse wiring. Please pay attention to terminal wiring sequence.
- 3) Keep controller in an environmental temperature from -20°C~+55°C. Avoid direct sunlight.
- 4) Keep good heat dissipation.
- 5) Use the pure copper wires and connect all polarity correctly.
- 6) Please don't set any parameters if you are not professional since the controller can work fine in default condition except lithium battery.

#### Air Circuit Breaker and Wires Requirement

Models	M4880F	M48100F
Copper wires	>12mm <sup>2</sup>	>15mm <sup>2</sup>
Air circuit breakers	100A	120A

#### Wire Connection Sequences

- Connect the positive battery wire followed by the negative battery wire.
- Connect the positive solar array out put wire followed by the negative solar array.

#### Device Diagram

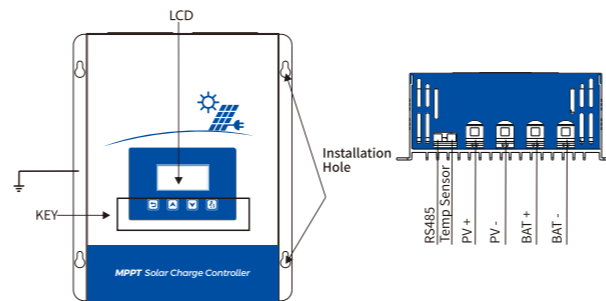

#### Installation Steps

1. The battery voltage should be more than 8V, then the controller can boot up. Install air circuit breaker between controller and batteries. Turn off the circuit breaker, then connect batteries to controller with correct polarity.
2. Install DC breaker between controller and PV modules. Turn off the DC breaker, and ensure the PV polarity correct, then connect wires between PV modules and controller.
3. Turn on the DC breaker between controller and batteries.
4. Turn on the DC breaker between controller and PV modules.

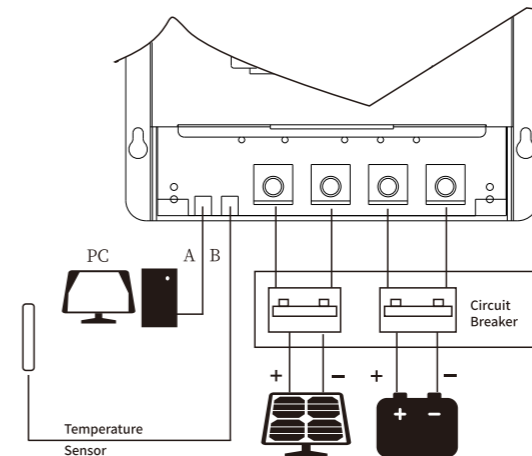
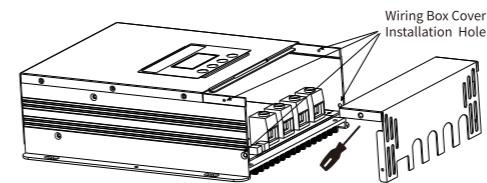

#### LCD Display Indication

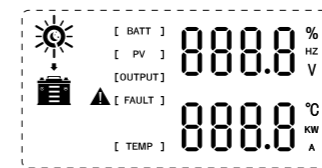

#### 1. Display Introduction

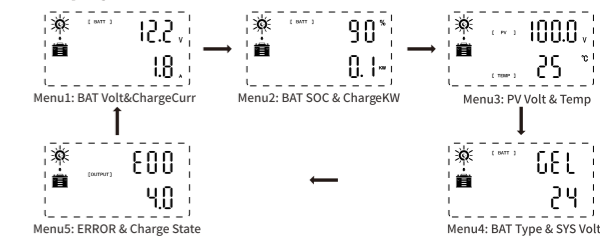

#### 2. Battery Type Setting

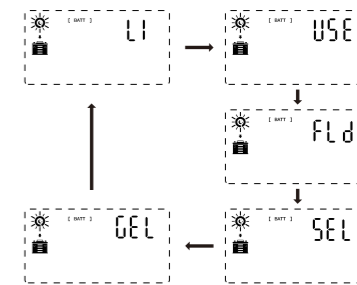

#### 3. System Voltage Setting

(1) Battery Type = USE

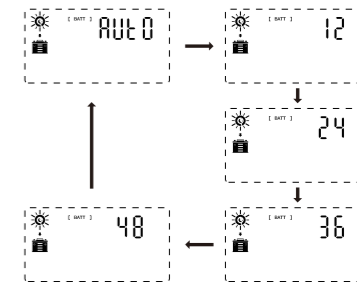

(2) Battery Type = LI

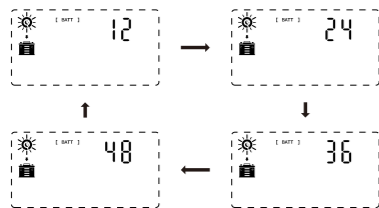

(3) Battery Type = SEL/GEL/FLD



4. Parameter Setting

(1) Battery Type = USE

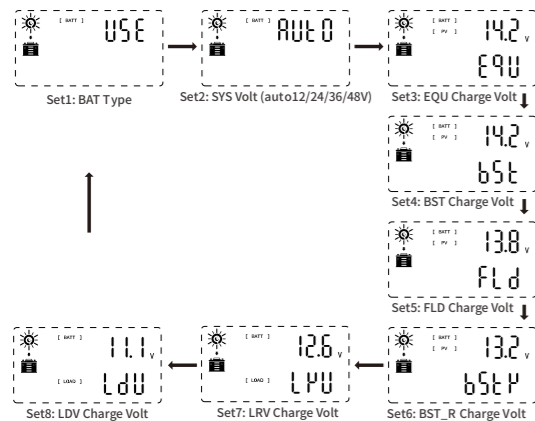

(2) Battery Type = LI

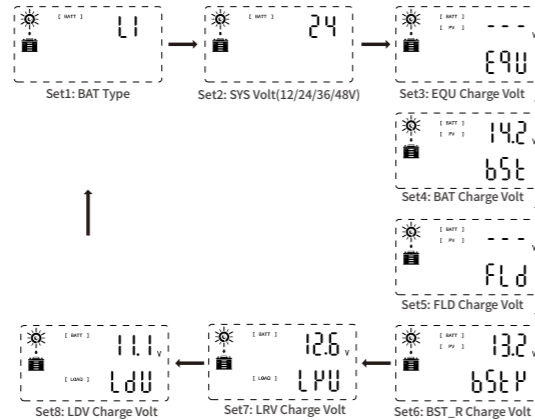

(3) Battery Type = SEL/GEL/FLD

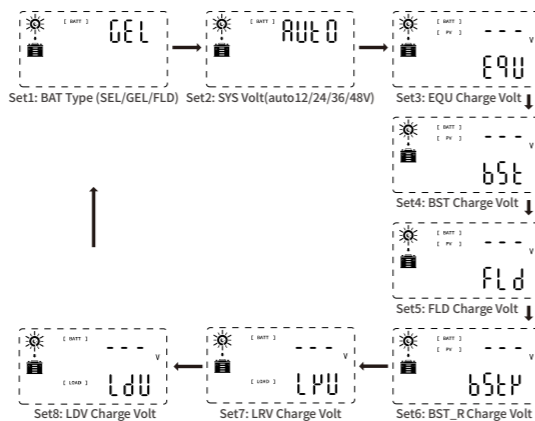

Press Key Operation

Function Key	System Mode	Operation	Operation Indication
[Enter]	View Mode	Long Press	Enter SET mode
[Up]	View Mode	Short Press	Screen page down
[Down]	View Mode	Short Press	Screen page up
[ESC]	View Mode	Short Press	-

Function Key	System Mode	Operation	Operation Indication
[Enter]	Setting Mode	Long Press	Exit from setting & saving the present setting data
[Enter]		Short Press	Enter the next setting page
[Up]	Setting Mode	Short Press	Adjust the parameter by increase the value
[Down]	Setting Mode	Short Press	Adjust the parameter by decrease the value
[ESC]	Setting Mode	Short Press	Exit SET Mode with out saving data

Error Code

Code	Error
E01	Battery Over Voltage
E02	PV Over Voltage
E08	Over-discharge
E13	Solar Reverse Polarity
E14	Battery Reverse Polarity
E20	Device Over Heating

Working Mode

Code	Working Mode
3.0	Night Mode, No Charging
4.0	MPPT Mode
7.0	Boost Mode
8.0	Floating Mode

Batteries charge voltage reference

Battery Type	System Volt	EQU	BST	FLD	BST_R	LRV	LDV
GEL	Auto	---	14.2V	13.8V	13.2V	12.6V	11.1V
SEL	Auto	14.6V	14.4V	13.8V	13.2V	12.6V	11.1V
FLD	Auto	14.8V	14.6V	13.8V	13.2V	12.6V	11.1V
USE	Auto/12/24/36/48	Defined by GEL					
LI	12/24/36/48	---	Defined by GEL	---	---	---	Defined by GEL

\*Note: Please set according to the 12V parameters in the table above, and the controller program will automatically multiply the relative multiples. For example, for 24V lithium battery parameter setting, first select lithium battery mode, select 24V battery system, and then set BOOST Voltage to 14.2V, save and exit the settings.

Dimension

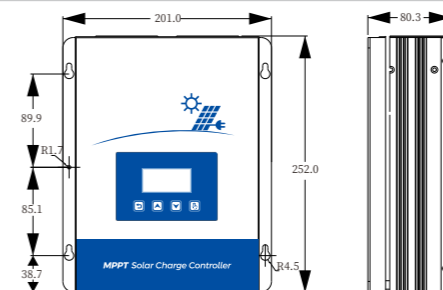

Basic Parameter

Item	Parameter	
Models	M4880F	M48100F
Charging Mode	3-stage: Constant Current(MPPT), Constant Voltage, Floating	
System Voltage	12/24/36/48/Auto	
Max PV Input Power	1200W/12V; 2400W/24V 3600W/36V; 4800W/48V	1500W/12V; 3000W/24V 4500W/36V; 6000W/48V
Max PV Input Voltage	150 Voc	
Battery Voltage Automatic Recognition	12V System(DC8.7V-DC15.5V) 24V System(DC16V -DC31V) 36V System(DC33V -DC41V) 48V System(DC42V -DC64V)	
Overcharging Protection Voltage	12V System(16V) 24V System(32V) 36V System(48V) 48V System(64V)	
Limited Current Protection	80A	100A
Max Efficiency	≥98.1%	
PV Utilization	≥99%	
Auto Temperature Compensation	-3mV/2V/°C	
Protection Function		
Temperature Protection	80°C	
Fan-on Temperature	>45°C	
Fan-off Temperature	<40°C	
Properties		
Size(mm)	252*201*80.3	
Net Weight(Kg)	2.28	2.49
Electromagnetic Compatibility	Accord to EN61000, EN55022, EN55024	
Enclosure	IP21	
Environmental Temperature	-20°C~+55°C	
Storage Temperature	-40°C~+75°C	