



**APPROVAL SHEET
FOR
MYLAR SPEAKER**

常州富鸿达电子有限公司

CHANG ZHOU FHD ELECTRONICS CO., LTD.

CUSTOMER No.:

CLUE No.:

MODEL No.: FHDDMT28A-001

OUR PART No.:

PART No.:

CUSTOMER	APPROVED	CHECKED

Add: Xujia Industrial Park, ZhenLu Town, Changzhou City, Jiangsu China.

江苏省常州市天宁区郑陆镇工业大道2号

Tel: +86-519-83822009

Fax: +86-519-88739926

Email: sales@czfhd.com; <http://www.czfhd.com>

Specification for mylar speaker			Update	Page 2 of 5
			Des.	Chk.
Model No.:	FHDDMT28A-001	P/N:	Xu Fei	
			8/18/2021	8/18/2021

1. Document revision history

修改时间	版本	修改页次	修改内容	确认人

Specification for mylar speaker		Update	Page 3 of 5
		Des.	Chk.
Model No.:	FHDDMT28A-001	P/N:	Xu Fei
			8/18/2021

2. SPECIFICATION

Speaker

1	Dimension	Φ28*H11.3mm
2	Impedance	40hm ± 20% at 1KHz
3	Rated Input Power	3.0W
4	Max Input Power	3.5W
5	Lowest Resonance Frequency	450±20%Hz @ 1V. (Without Baffler)
6	Audible Noise	The input power shall be set at rated noise power(3.0W). Using an audio oscillator sweep from F0 to 20KHZ in free air. There shall be no buzzes,rattles,nor spurious noises.
7	Sound Pressure Level	95±3dB SPL(0.1m,1.0W) at1.0KHz (0dB SPL=20 μ Pa)
8	Distortion	Less exceed ≤10% at 1.0KHz
9	Operating Temperature	-20°C to + 50°C
10	Store Temperature	-30°C to + 60°C

3. Dimensions

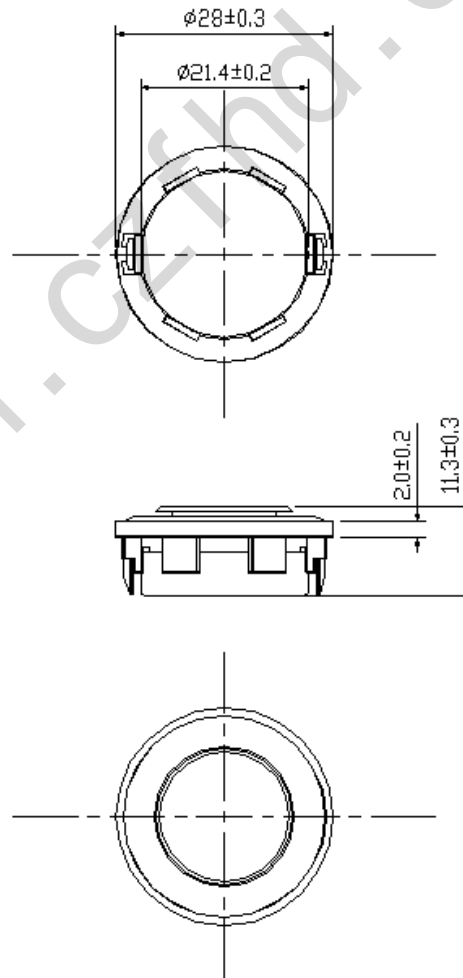

Specification for mylar speaker		Update	Page 4 of 5
		Des.	Chk.
Model No.:	FHDDMT28A-001	P/N:	Xu Fei
			8/18/2021

4. Reliability Test 可靠性測試

4.1	High Temperature Test	High Temperature: +60°C±3°C Duration : 48 hours
4.2	Low Temperature Test	Low Temperature: -30°C±3°C Duration : 48 hours
4.3	Humidity Test	Temperature: +40°C±3°C Relative humidity: 90%~95% RH Duration : 48 hours
4.4	Vibration Test	Vibration: 10Hz~55Hz Amplitude: 1.52mm or acceleration : 50m/s2 Duration : 2h per axis=10 cycles ; 3 axis
4.5	Temperature Cycle Test	Temperature: -30°C ↔ +60°C Duration : 1 hours 1 hours Cycle: 5 Cycle
4.6	Drop Test (under the unit)	Height: 1.0m Cycle: 5 Cycles
4.7	Load Test	Noise: White noise Power: 3.0W Duration: 48 hours and satisfy the test listed on item 05,08,14.

The test shall be carried out on the parts that passed 12hours in temperature 20°C.
The sensitivity difference from the initial value shall be within ±3dB.

Specification for mylar speaker			Update	Page 5 of 5
Model No.:	FHDDMT28A-001	P/N:	Des.	Chk.
			Xu Fei	
			8/18/2021	8/18/2021

5. Electrical And Acoustical Measuring Condition

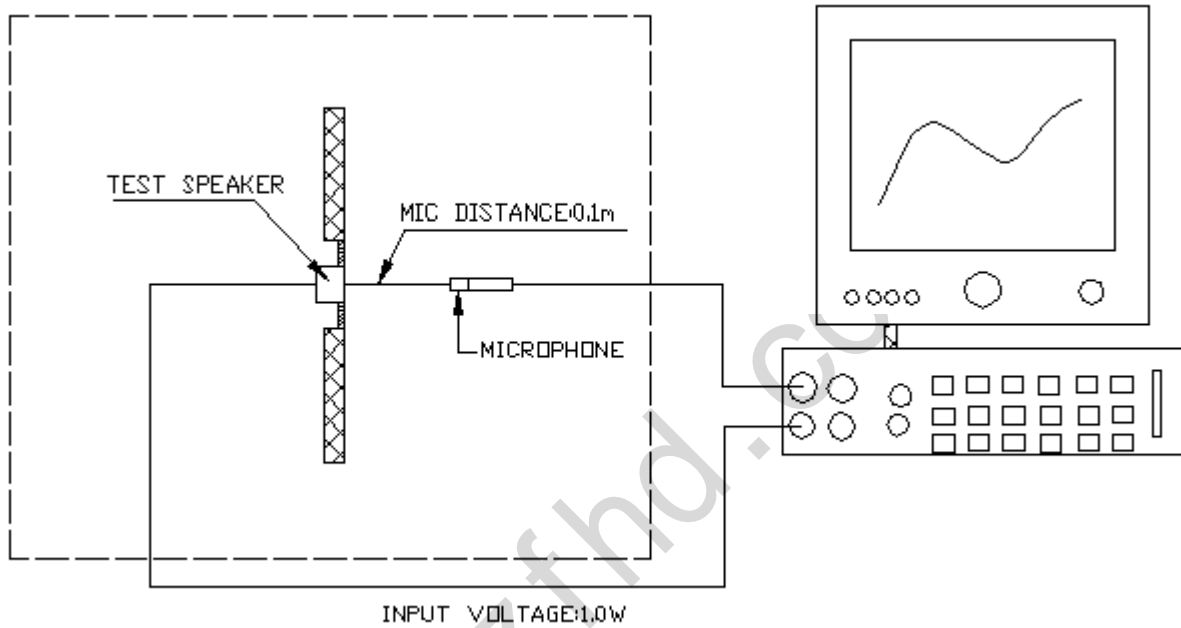

6. Frequency Response

