



ANSI/EIA-481-D-2008
Approved: July 29, 2008

EIA STANDARD

8 mm THROUGH 200 mm EMBOSSED CARRIER TAPING AND 8 mm & 12 mm PUNCHED CARRIER TAPING OF SURFACE MOUNT COMPONENTS FOR AUTOMATIC HANDLING

EIA-481-D
(Revision of EIA-481-C)

JULY 2008



EIA Standards
Electronic Components Association

EIA-481-D

NOTICE

EIA Engineering Standards and Publications are designed to serve the public interest through eliminating misunderstandings between manufacturers and purchasers, facilitating interchangeability and improvement of products, and assisting the purchaser in selecting and obtaining with minimum delay the proper product for his particular need. Existence of such Standards and Publications shall not in any respect preclude any member or nonmember of EIA from manufacturing or selling products not conforming to such Standards and Publications, nor shall the existence of such Standards and Publications preclude their voluntary use by those other than EIA members, whether the standard is to be used either domestically or internationally.

Standards and Publications are adopted by EIA in accordance with the American National Standards Institute (ANSI) patent policy. By such action, EIA does not assume any liability to any patent owner, nor does it assume any obligation whatever to parties adopting the Standard or Publication.

This EIA Standard is considered to have International Standardization implication, but the International Electrotechnical Commission activity has not progressed to the point where a valid comparison between the EIA Standard and the IEC document can be made.

This Standard does not purport to address all safety problems associated with its use or all applicable regulatory requirements. It is the responsibility of the user of this Standard to establish appropriate safety and health practices and to determine the applicability of regulatory limitations before its use.

(From Standards Proposal No. 5173 formulated under the cognizance of the Automatic Component Handling Committee).

Published by:

©ELECTRONIC COMPONENTS ASSOCIATION 2008
EIA Standards and Technology Department
2500 Wilson Boulevard – Suite 310
Arlington, VA 22201

PRICE: Please call:
Global Engineering Documents, USA and Canada (1-800-854-7179)
www.global.ihs.com

All rights reserved
Printed in U.S.A.

**PLEASE !
DON'T VIOLATE
THE
LAW!**

This document is copyrighted by the EIA and may not be reproduced without permission.

Organizations may obtain permission to reproduce a limited number of copies through entering into a license agreement. For information, contact:

Global Engineering Documents
15 Inverness Way East
Englewood, CO 80112-5704 or call
USA and Canada (1-800-854-7179), International (303-397-7956)

**8 mm THROUGH 200 mm EMBOSSED CARRIER TAPING
AND
8 mm & 12 mm PUNCHED CARRIER TAPING OF
SURFACE MOUNT COMPONENTS FOR AUTOMATIC HANDLING**

CONTENTS

	Page
1 SCOPE	1
2 INTRODUCTION	1
3 APPLICABLE DOCUMENTS	1
4 REQUIREMENTS	1-4
5 ACKNOWLEDGEMENTS	22
6 ADDENDUM	23

Figures

Figure 1	Component orientation and quadrant designations	6
Figure 2	Orientation Guide for Commonly Used Devices	7
Figure 3	Rules for determining orientation of component in tape pocket	8-9
Figure 4	8 mm & 12 mm punched carrier tape dimensions	10
Figure 5	Illustration of 2 mm cavity pitch for 8 mm & 12 mm punched and embossed carrier, P ₁	10
Figure 6	8 mm, 12 mm, 16 mm & 24 mm embossed carrier tape dimensions	12
Figure 7	32, 44, 56, 72, 88, 104, 120, 136, 152, 168, 184 & 200 mm embossed carrier tape dimensions	14
Figure 8	Maximum component rotation for punched and embossed carrier	16
Figure 9	Maximum lateral movement for punched and embossed carrier	16
Figure 10	Bar code label area for punched and embossed carrier	16
Figure 11	Bending radius for punched and embossed carrier	16
Figure 12	Maximum camber for punched and embossed carrier	17
Figure 13	Tape leader & trailer dimensions for punched and embossed carrier	18
Figure 14	Reel dimensions	20

Tables

Table 1	8 mm & 12 mm punched carrier dimensions	11
Table 2	8, 12, 16 & 24 mm embossed carrier dimensions	13
Table 3	32, 44, 56, 72, 88, 104, 120, 136, 152, 168, 184 & 200 mm embossed carrier dimensions	15
Table 4	Reel dimensions	21

Left intentionally blank.

8 mm THROUGH 200 mm EMBOSSED CARRIER TAPING
AND
8 mm & 12 mm PUNCHED CARRIER TAPING OF
SURFACE MOUNT COMPONENTS FOR AUTOMATIC HANDLING

(From Standards Proposal 5173, formulated under the cognizance of the EIA Automated Component Handling Committee (ACH).

1 Scope

This Standard covers requirements for taping surface mount components. Complementary standards for specialized taping requirements are included in the addendum.

2 Introduction

This Standard was formulated to provide dimensions and tolerances necessary to tape surface mount components such that they may be automatically handled.

3 Applicable Documents

Unless otherwise specified the following documents form a part of this standard to the extent specified herein:

EIA-383 "Preparation for the Delivery of Electrical and Electronic Components"

EIA-541 "Packaging Material Standards for ESD Sensitive Items"

EIA-556 "Electronic Industries Association Outer Shipping Container Bar Code Label Standard"

EIA-583 "Packaging Material Standards for Moisture Sensitive Items"

EIA-624 "Product Package Bar Code Label Standard for Non-Retail Applications"

JED95 "JEDEC Registered and Standard Outlines for Solid State and Related Products"

IPC 7351 "Generic Requirements for Surface Mount Design and Land Pattern Standard"

4 Requirements

4.1 Carrier tapes, cover tapes, reels, and taped components must meet the requirements defined in the Figures and Tables presented herein.

4.2 Procurement documents and quotation requests shall include the following information:

- (a) Reference to this Standard by Title and Number.

- (b) Taping quality requirements including maximum number of missing components.
- (c) Container and reel marking requirements (including bar code labeling if required), and reel diameter (refer to 4.12 and Figure 10).
- (d) Shipping conditions, storage conditions and storage time.
- (e) Weight of the reel containing components. NOTE: A heavy reel may not work on all feeders. Also, a reel containing components attached to a feeder may exceed regulatory or corporate weight limits for lifting by workers.

4.3 Several conditions exist that may cause functional problems with carrier tapes and/or tape feeding systems even though the dimensions are within the parameters specified in the tables and figures of this document:

- (a) Based on the carrier style, tape thickness T , tape cavity depth T_2 , outside pocket width B_1 , the cavity pitch P_1 , or the reel flange diameter A , the following conditions may cause problems with tape feeding systems and should be considered as part of the procurement documents and quotation requests as applicable:

Type (Punched/Embossed)	Tape Width (mm)	Dimension (mm)	See Figure
Punched/Embossed	8, 12	$A > 360$	14
Embossed	8	$B_1 > 4.2$	6
Punched	8, 12	$T > 1.1$	4
Embossed	8, 12	$P_1 = 2.0$	5
Punched	12	$P_1 = 2.0$	5
Embossed	12	$T_2 > 4.5$	6
Embossed	16, 24	$T_2 > 6.5$	6
Embossed	32 to 200	$T_2 > 10.1$	7
Embossed	72 to 200	$P_1 > 56$	7

- (b) For 8, 12, 16 and 24 mm wide embossed tapes, if $S_1 < 1.0$ mm (Table 2 and Figure 6), there may not be enough area to obtain a proper seal between the carrier and cover tapes according to paragraphs 4.5 and 4.11 and must be considered as part of the procurement documents and quotation requests as applicable.
- (c) Users may experience problems feeding low mass components due to electrostatic effects (attraction and/or repulsion) associated with the separation of the cover tape and carrier tape during the feeding operation. The result of this phenomenon could cause devices to migrate, or be propelled away from the user pick up point, resulting in a mis-pick or non-pick situation during placement. To minimize this phenomenon, it is recommended that the packaging materials, component placement equipment, and controlled environmental conditions be optimized to effectively dissipate any charge buildup. This charge, commonly referred to as tribo-electric charge, should be controlled per the guidelines in EIA-541.

(d) Carrier tapes may experience feeding problems when passed through tracks with lengths in excess of 250 mm. Figure 12 outlines the suggested measurement of camber.

(e) Camber in excess of 1 mm over 250 mm may be generated when empty carrier tape is supplied on level-wound reels.

4.4 Components are to be prevented from falling out of the cavity of the carrier tape, and shall remain in position for automatic handling after removal of the top cover tape (see Note 1, Tables 1, 2 & 3).

4.5 The cover tape(s) may not extend over the edge of the carrier tape or cover any part of the sprocket holes.

4.6 Tape in adjacent layers shall not stick together when wound on the carrier reel.

4.7 The packaging, materials and processes shall not adversely affect the mechanical and electrical characteristics or marking of the components. For intermediate and final packaging, refer to EIA-383 "Preparation for the Delivery of Electrical and Electronic Components," EIA-541 "Packaging Material Standards for ESD Sensitive Items," and EIA-583 "Packaging Material Standards for Moisture Sensitive Items," and EIA-624 "Product Package Bar Code Label Standard for Non-Retail Applications."

4.8 The tapes shall be suitable to withstand storage of the taped components without danger of migration of contaminants onto the terminations, or the emission of vapors which would make soldering difficult or deteriorate the component properties or terminations by chemical action. In addition, the cover tape(s) shall not become detached, such that the components do not remain in position after storage. The punched carrier material shall not age and lose strength such that it breaks or delaminates on unreeling when the taped components are fed from the package by hand or into the assembly machines (refer to 4.2(d)).

4.9 Components may be removed from the cavity by incising the bottom cover tape (see Figure 10) for punched carrier tape, or in the case of embossed carrier, by incising at or below the cavity depth midpoint ($K_0/2$). In no case shall the incising affect the package functionality.

4.10 There shall not be consecutive components missing from any reel for any reason.

4.11 The cover tape for each style and material of carrier tape shall have a total peel strength of from 0.1 N to 1.0 N (10 grams to 100 grams calibrated scale reading) for 8 mm carrier tapes and from 0.1 N to 1.3 N (10 grams to 130 grams calibrated scale reading) for 12 mm to 56 mm wide carrier tapes and from 0.1 N to 1.5 N (10 grams to 150 grams calibrated scale reading) for 72 mm and wider carrier tapes. Peel is defined as the separation of the full width of the cover tape from the carrier tape or the removal of the center portion of the cover tape from the carrier tape to enable component removal from the cavity. The direction of pull shall be opposite the direction of carrier tape travel such that the cover tape makes an angle of between 165 and 180 degrees with the top of the carrier tape. The cover tape, shall be pulled with a velocity of 300

mm +/- 10 mm/minute, relative to the carrier tape, during peeling, which results in the cover/carrier tape seal being separated at a rate of 150 mm/minute.

4.12 Bar code labeling (if required) shall be on the side of the reel opposite the round sprocket holes (refer to 4.2(c) and Figure 10). Refer to EIA-556 and EIA-624.

4.13 Reels as defined by Figure 14 shall be permanently marked with visible recycling symbology.

4.14 The following orientation rules shall be considered as standard for multi-connection components.

- (a) Traditionally packaged components with leaded, bottom-only terminations (e.g. PLCC, SOIC, SOJ, and BGA) shall be packaged with the terminations facing the bottom of the carrier cavity. The following rules apply whether the terminations are facing downward or upward in the cavity.
- (b) Termination is the electrical or mechanical connection from the component to the board and can be described as lead, pin, bump, ball, wirepad, connector, etc.
- (c) Orienting feature is the attribute on the component that identifies a unique orientation. The most accurate description should be Termination 1 (refer to IPC 7351); however in absence of Termination 1 definition, the following features can be used: fiducial mark, chamfered edge, dimple, notch, wider termination, etc. If the orienting feature is located in the exact center of the component, or it lies on the shorter axis of the component, then an alternate orienting feature on the component should be chosen.
- (d) A component is considered square if the bounding rectangle around the outer extents of the component (including body and terminations) contains edges with a difference no greater than 0.3mm between the nominal length and width.
- (e) The tape pocket quadrant designations that describe the taped orientation of components are shown in Figure 1.
- (f) For existing Component Packages use Figure 2 "Orientation Guide for Commonly Used Devices".
- (g) If a package type is not contained in Figure 2, use the rules in the sequence shown in the following flow chart (Figure 3) to determine the correct orientation of the component in the tape pocket.

Left intentionally blank.

Figure 1 -- Component orientation and quadrant designations

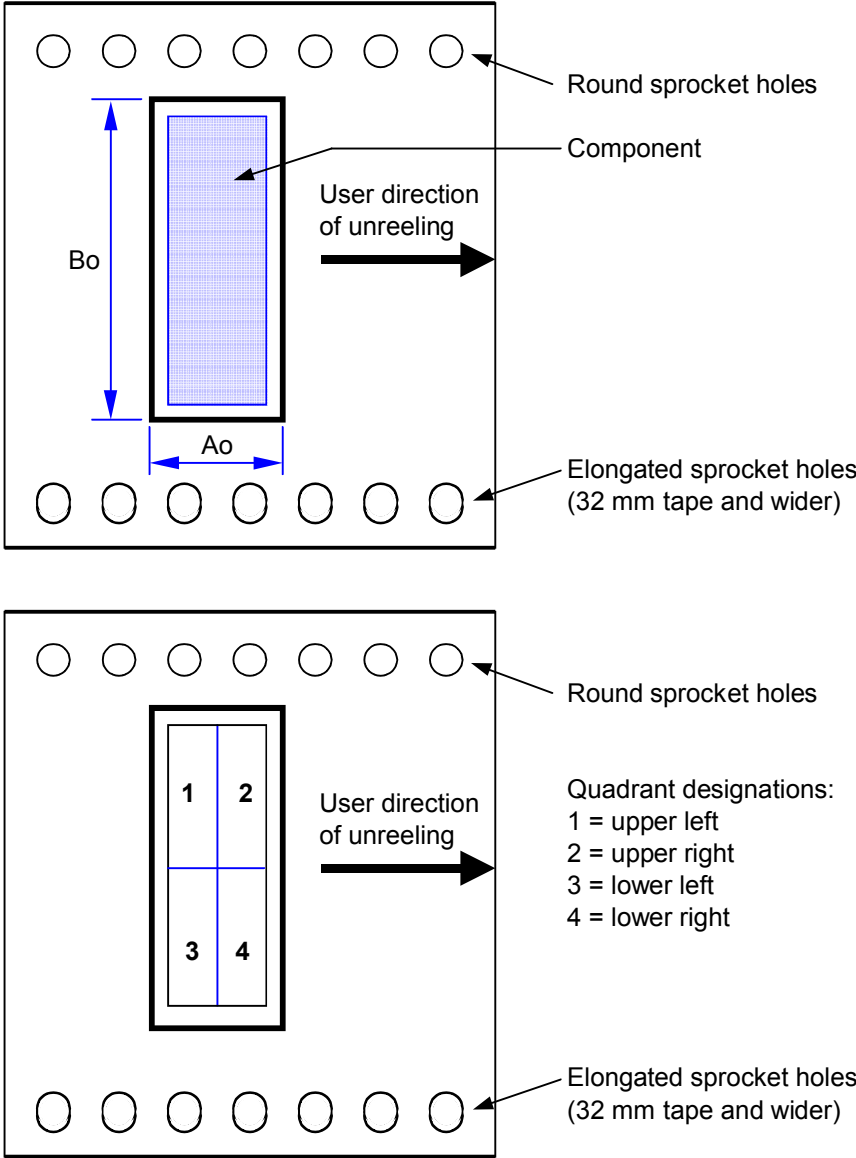

Figure 2 – Orientation Guide for Commonly Used Devices



DIRECTION OF UNREELING

Component Package	SOT23	SOT223	SOT143	SOT89	SOT343																				
Orientation in carrier																									
Termination 1 Orientation by Quadrant	<table border="1"> <tr><td>1</td><td>2</td></tr> <tr><td>3</td><td>4</td></tr> </table>	1	2	3	4	<table border="1"> <tr><td>1</td><td>2</td></tr> <tr><td>3</td><td>4</td></tr> </table>	1	2	3	4	<table border="1"> <tr><td>1</td><td>2</td></tr> <tr><td>3</td><td>4</td></tr> </table>	1	2	3	4	<table border="1"> <tr><td>1</td><td>2</td></tr> <tr><td>3</td><td>4</td></tr> </table>	1	2	3	4	<table border="1"> <tr><td>1</td><td>2</td></tr> <tr><td>3</td><td>4</td></tr> </table>	1	2	3	4
1	2																								
3	4																								
1	2																								
3	4																								
1	2																								
3	4																								
1	2																								
3	4																								
1	2																								
3	4																								
Component Package	SOT23-5 / SC70-5 / SSOP-5	SOT23-6 / SC70-6 / SSOT-6	TO-89	DPAK / D2PAK / TO-252 / TO-220	D2PAK-5P / TO-263-5																				
Orientation in carrier																									
Termination 1 Orientation by Quadrant	<table border="1"> <tr><td>1</td><td>2</td></tr> <tr><td>3</td><td>4</td></tr> </table>	1	2	3	4	<table border="1"> <tr><td>1</td><td>2</td></tr> <tr><td>3</td><td>4</td></tr> </table>	1	2	3	4	<table border="1"> <tr><td>1</td><td>2</td></tr> <tr><td>3</td><td>4</td></tr> </table>	1	2	3	4	<table border="1"> <tr><td>1</td><td>2</td></tr> <tr><td>3</td><td>4</td></tr> </table>	1	2	3	4	<table border="1"> <tr><td>1</td><td>2</td></tr> <tr><td>3</td><td>4</td></tr> </table>	1	2	3	4
1	2																								
3	4																								
1	2																								
3	4																								
1	2																								
3	4																								
1	2																								
3	4																								
1	2																								
3	4																								
Component Package	QFP	TSOP	PLCC	SOIC	DIP																				
Orientation in carrier																									
Termination 1 Orientation by Quadrant	<table border="1"> <tr><td>1</td><td>2</td></tr> <tr><td>3</td><td>4</td></tr> </table>	1	2	3	4	<table border="1"> <tr><td>1</td><td>2</td></tr> <tr><td>3</td><td>4</td></tr> </table>	1	2	3	4	<table border="1"> <tr><td>1</td><td>2</td></tr> <tr><td>3</td><td>4</td></tr> </table>	1	2	3	4	<table border="1"> <tr><td>1</td><td>2</td></tr> <tr><td>3</td><td>4</td></tr> </table>	1	2	3	4	<table border="1"> <tr><td>1</td><td>2</td></tr> <tr><td>3</td><td>4</td></tr> </table>	1	2	3	4
1	2																								
3	4																								
1	2																								
3	4																								
1	2																								
3	4																								
1	2																								
3	4																								
1	2																								
3	4																								
Component Package	QFN (Square geometry)	QFN (Rectangular geometry)	BGA (Square geometry)	BGA (Rectangular geometry)	LCC																				
Orientation in carrier																									
Termination 1 Orientation by Quadrant	<table border="1"> <tr><td>1</td><td>2</td></tr> <tr><td>3</td><td>4</td></tr> </table>	1	2	3	4	<table border="1"> <tr><td>1</td><td>2</td></tr> <tr><td>3</td><td>4</td></tr> </table>	1	2	3	4	<table border="1"> <tr><td>1</td><td>2</td></tr> <tr><td>3</td><td>4</td></tr> </table>	1	2	3	4	<table border="1"> <tr><td>1</td><td>2</td></tr> <tr><td>3</td><td>4</td></tr> </table>	1	2	3	4	<table border="1"> <tr><td>1</td><td>2</td></tr> <tr><td>3</td><td>4</td></tr> </table>	1	2	3	4
1	2																								
3	4																								
1	2																								
3	4																								
1	2																								
3	4																								
1	2																								
3	4																								
1	2																								
3	4																								
Component Package	SSOP / TSSOP / MSOP	Ultra Thin SO8 (US8)	Tantalum Capacitor	DIODE / LED	Connectors (square or rectangular)																				
Orientation in carrier																									
Termination 1 Orientation by Quadrant	<table border="1"> <tr><td>1</td><td>2</td></tr> <tr><td>3</td><td>4</td></tr> </table>	1	2	3	4	<table border="1"> <tr><td>1</td><td>2</td></tr> <tr><td>3</td><td>4</td></tr> </table>	1	2	3	4	<table border="1"> <tr><td>1</td><td>2</td></tr> <tr><td>3</td><td>4</td></tr> </table>	1	2	3	4	<table border="1"> <tr><td>1</td><td>2</td></tr> <tr><td>3</td><td>4</td></tr> </table>	1	2	3	4	<table border="1"> <tr><td>1</td><td>2</td></tr> <tr><td>3</td><td>4</td></tr> </table>	1	2	3	4
1	2																								
3	4																								
1	2																								
3	4																								
1	2																								
3	4																								
1	2																								
3	4																								
1	2																								
3	4																								

Figure 3 -- Rules for determining orientation of component in tape pocket (1 of 2)

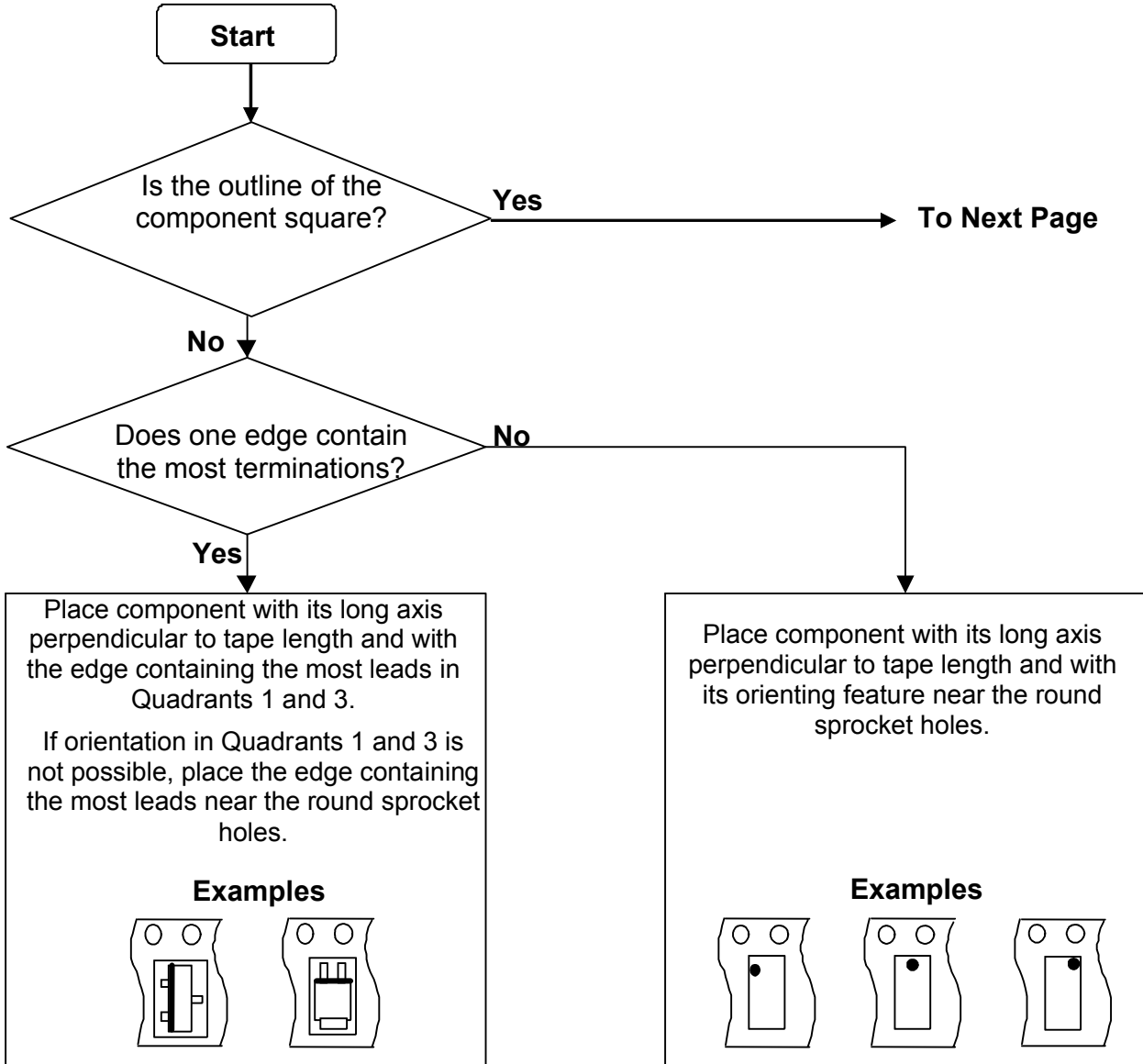

Figure 3 -- Rules for determining orientation of component in tape pocket (2 of 2)

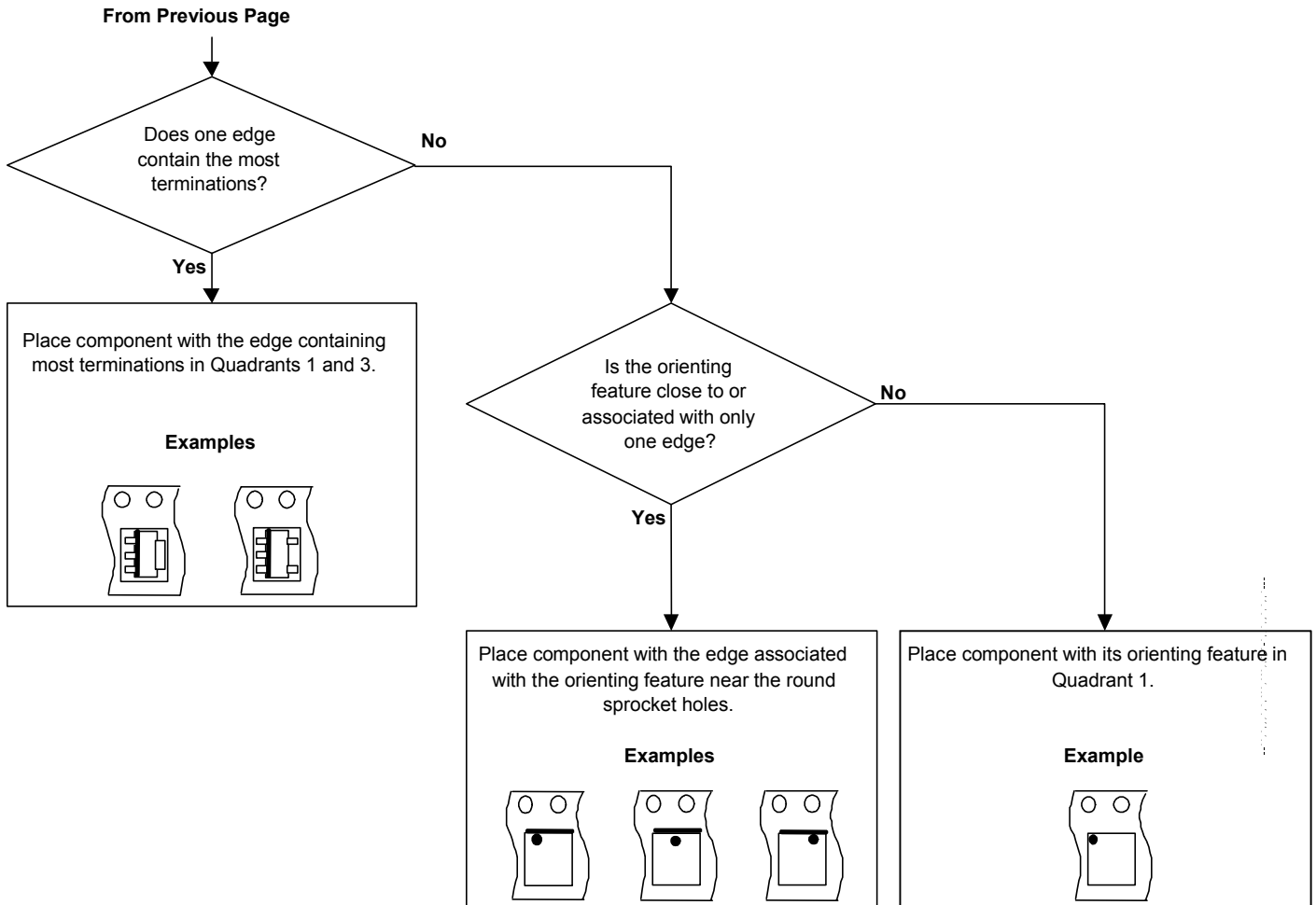

Figure 4 -- 8 mm & 12 mm punched carrier tape dimensions
See Section 4.0 for requirements (all dimensions in millimeters)

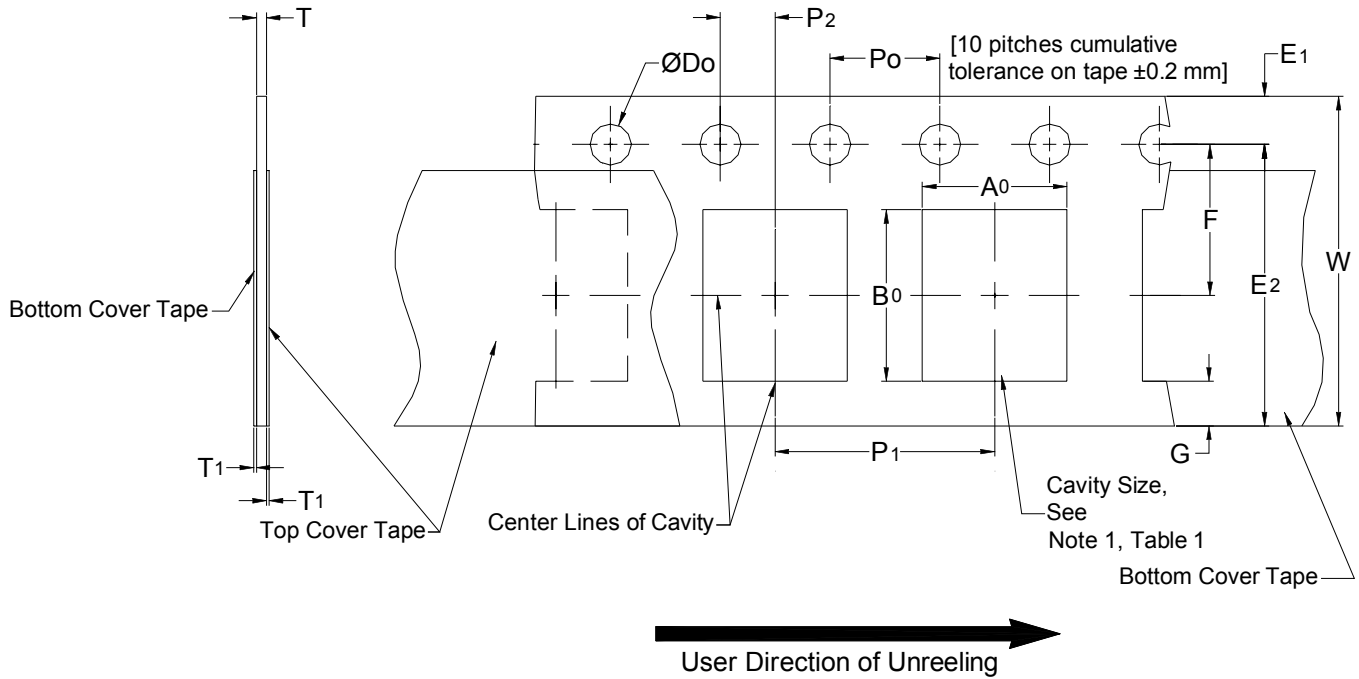

Figure 5 -- Illustration of 2 mm cavity pitch for 8 mm & 12 mm punched and embossed carrier, P1.
See Tables 1 & 2 and requirement 4.3

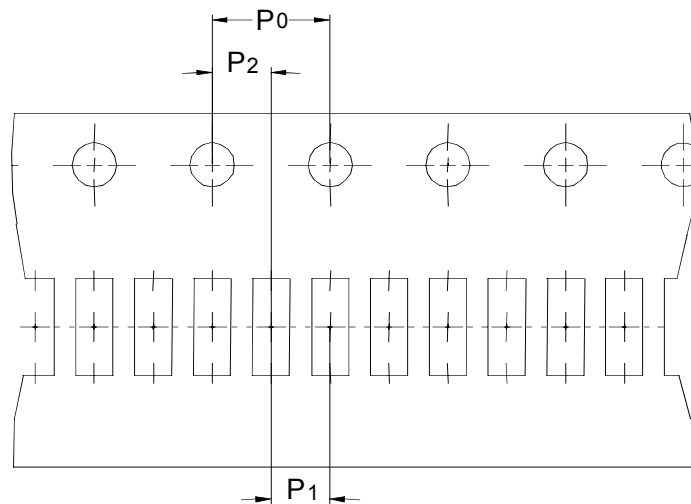

Table 1 -- 8 & 12 mm punched carrier dimensions
(all dimensions in millimeters)

Constant Dimensions

Tape Size	D ₀	E ₁	P ₀	P ₂	T ₁ Max.	G Min.	R Ref. See Note 2
8 mm & 12 mm	1.5 +0.1 -0.0	1.75± 0.1	4.0 ±0.1	2.0±0.05	0.1	0.75	25

Variable Dimensions

Tape Size	E ₂ Min.	F	P ₁	W Max.	A ₀ B ₀	T
8 mm	6.25	3.5± 0.05	2.0±0.05 or 4.0±0.1	8.3	See Note 1	1.1 mm maximum for Paper Base Tape, and 1.6 mm maximum for Non-Paper Base Compositions. See Note 2 and Requirement 4.3
12 mm	10.25	5.5± 0.05	2.0±0.05, 4.0±0.1 or 8.0±0.1	12.3		

Notes

- 1 The cavity defined by A₀, B₀ and T shall surround the component with sufficient clearance that:
 - a) the component does not protrude beyond either surface of the carrier tape.
 - b) the component can be removed from the cavity in a vertical direction without mechanical restriction, after the top cover tape has been removed.
 - c) rotation of the component is limited to 20° maximum (see Figure 8).
 - d) lateral movement of the component is restricted to 0.5 mm maximum (see Figure 9).
 - e) see Addendum for standards relating to more precise taping requirements.
- 2 The tape with or without components shall pass around R without damage (see Figure 11).

Figure 6 -- 8 mm, 12 mm, 16 mm & 24 mm embossed carrier tape dimensions

See Section 4.0 for requirements (all dimensions in millimeters)

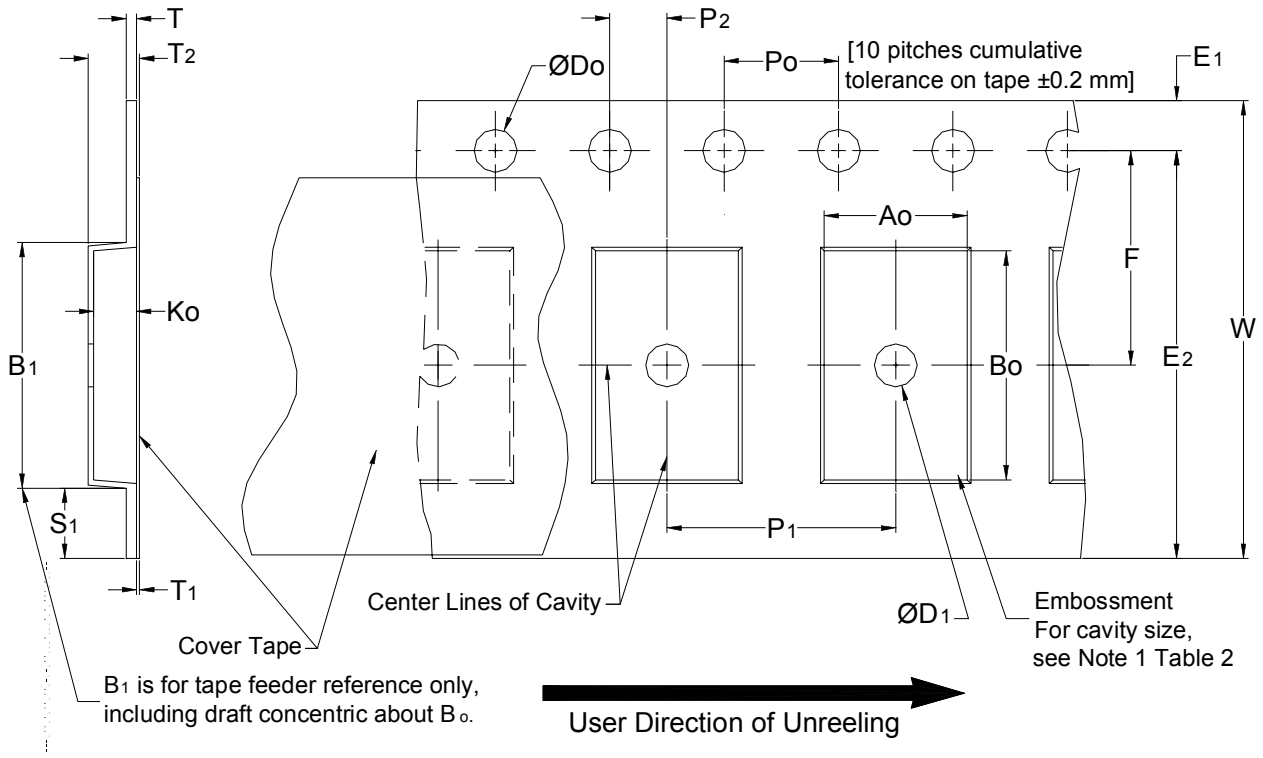

Table 2 -- 8, 12, 16 & 24 mm embossed carrier dimensions

Constant (for 2 or more widths) Dimensions

Tape Size	D ₀	D ₁ Min.	E ₁	P ₀	P ₂	R Ref. See Note 2	S ₁ Min. See Note 3	T Max.	T ₁ Max.
8 mm	1.5 +0.1 -0.0	1.0	1.75 ±0.1	4.0 ±0.1	2.0± 0.05	25	0.6	0.6	0.1
12 mm		1.5			2.0± 0.1	30			
16 mm									
24 mm									

Variable Dimensions

Tape Size	B ₁ Max.	E ₂ Min.	F	P ₁	T ₂ Max.	W Max	A ₀ , B ₀ & K ₀
8 mm	4.35	6.25	3.5± 0.05	2.0±0.05 or 4.0±0.10	2.5	8.3	See Note 1
12 mm	8.2	10.25	5.5± 0.05	2.0±0.05 or 4.0±0.1 or 8.0±0.1	6.5	12.3	
16 mm	12.1	14.25	7.5 ±0.1	4.0±0.1 to 12.0±0.1 in 4.0 increments	8.0	16.3	
24 mm	20.1	22.25	11.5 ±0.1	4.0±0.1 to 20.0±0.1 in 4.0 increments	12.0	24.3	

Notes

- 1 The cavity defined by A₀, B₀ and K₀ shall surround the component with sufficient clearance that:
 - (a) the component does not protrude above the top surface of the carrier tape.
 - (b) the component can be removed from the cavity in a vertical direction without mechanical restriction, after the top cover tape has been removed.
 - (c) rotation of the component is limited to 20° maximum for 8 and 12 mm tapes and 10° maximum for 16 mm and 24 mm tapes (see Figure 8).
 - (d) lateral movement of the component is restricted to 0.5 mm maximum for 8 mm and 12 mm wide tape and to 1.0 mm maximum for 16 mm, 24 mm wide tape (see Figure 9).
 - (e) see Addendum for standards relating to more precise taping requirements.
- 2 The tape with or without components shall pass around R without damage (see Figure 11).
- 3 If S₁ < 1.0 mm, there may not be enough area for cover tape to be properly applied (see paragraph 4.3 (b)).

Figure 7 -- 32, 44, 56, 72, 88, 104, 120, 136, 152, 168, 184 & 200 mm embossed carrier tape dimensions

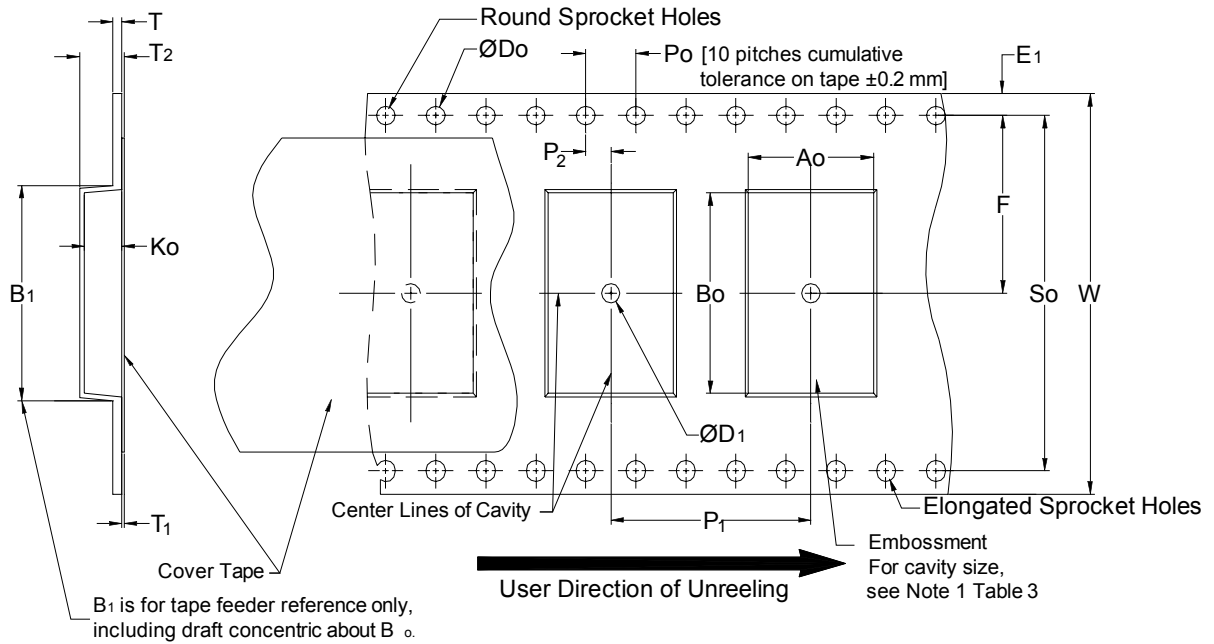

Detail, Elongation and Skew of Sprocket Holes

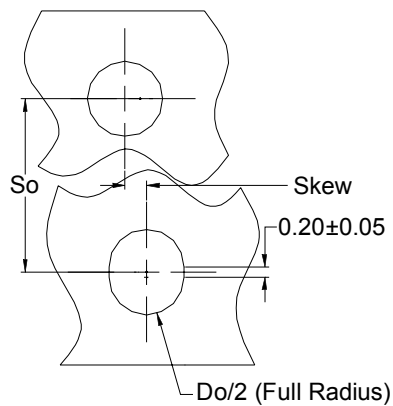

Tape Size	Skew, MAX.
32-56 mm	0.05 mm
72-88 mm	0.10 mm
104-152 mm	0.15 mm
168-200 mm	0.20 mm

Table 3 -- 32, 44, 56, 72, 88, 104, 120, 136, 152, 168, 184 & 200 mm embossed carrier dimensions

Constant Dimensions (for 2 or more widths)

Tape Size	D ₀	D ₁ Min.	E ₁	P ₀	P ₂	R Ref. See Note 2	T Max.	T ₁ Max.
32 mm	1.5+0.1 -0.0	2.0	1.75± 0.10	4.0± 0.1	2.0±0.1	50	0.6	0.1
44 mm					2.0±0.1			
56 mm					5			
72 mm through 200 mm					2.0±0.2	75		

Variable Dimensions

Tape Size	B ₁ Max.	F	P ₁ (in 4.0 increments)	S ₀	T ₂ Max.	W	A ₀ , B ₀ & K ₀
32 mm	23.0	14.2±0.10	4.0±0.1 to 32.0±0.1	28.4±0.1	12.0	32.0±0.3	See Note 1
44 mm	35.0	20.2±0.15	4.0±0.1 to 44.0±0.1	40.4±0.1	16.0	44.0±0.3	
56 mm	46.0	26.2 ±0.15	4.0±0.1 to 56.0±0.1	52.4±0.1	20.0	56.0±0.3	
72 mm	60.0	34.2±0.30	4.0±0.1 to 72.0±0.1	68.4±0.1	30.0	72.0±0.3	
88 mm	76.0	42.2±0.30		84.4±0.1		88.0±0.3	
104 mm	91.0	50.2±0.35		100.4±0.1	35.0	104.0±0.3	
120 mm	107.0	58.2±0.35		116.4±0.1	40.0	120.0±0.3	
136 mm	123.0	66.2±0.40		132.4±0.1		136.0±0.3	
152 mm	139.0	74.2±0.40		148.4±0.1		152.0±0.3	
168 mm	153.0	82.2±0.45		164.4±0.1		168.0±0.3	
184 mm	169.0	90.2±0.45		180.4±0.1		184.0±0.3	
200 mm	185.0	98.2±0.50		196.4±0.1		200.0±0.3	

Notes

- 1 The cavity defined by A₀, B₀ and K₀ shall surround the component with sufficient clearance that:
 - (a) the component does not protrude above the top surface of the carrier tape.
 - (b) the component can be removed from the cavity in a vertical direction without mechanical restriction, after the top cover tape has been removed.
 - (c) rotational limits of the component in the pocket are illustrated in Figure 8.
 - (d) lateral movement of the component is restricted to 1.0 mm maximum (see Figure 9).
- 2 The tape with or without components shall pass around R without damage (see Figure 11).

Figure 8 -- Maximum component rotation for punched and embossed carrier

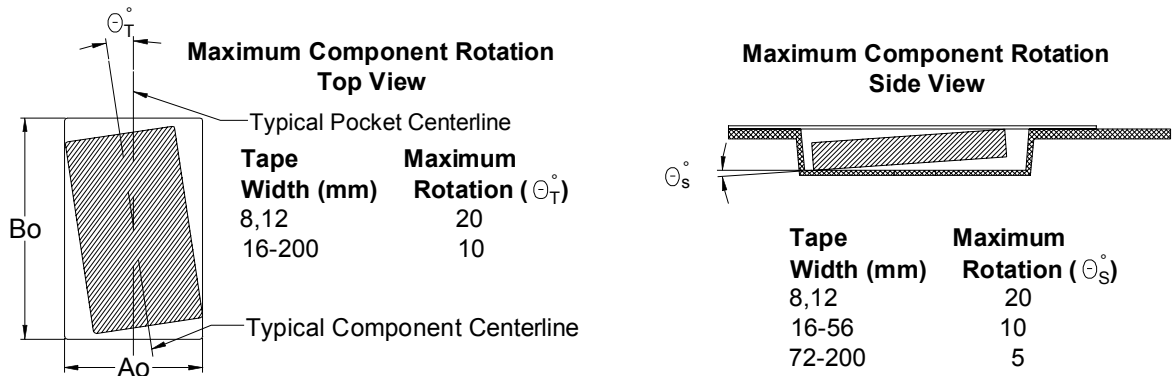

Figure 9 -- Maximum lateral movement for punched and embossed carrier

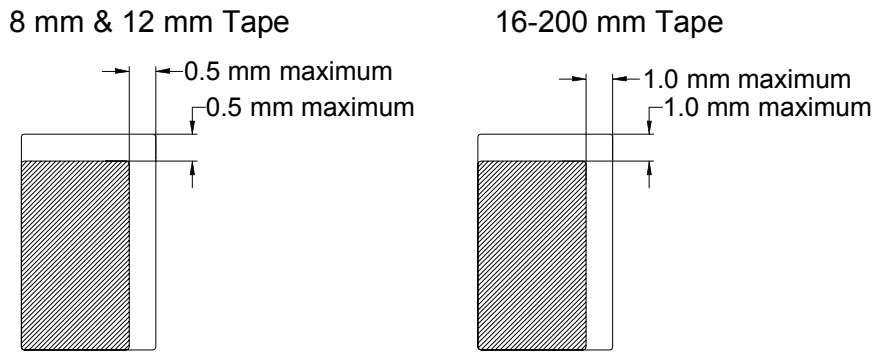

Figure 10 -- Bar code label area for punched and embossed carrier

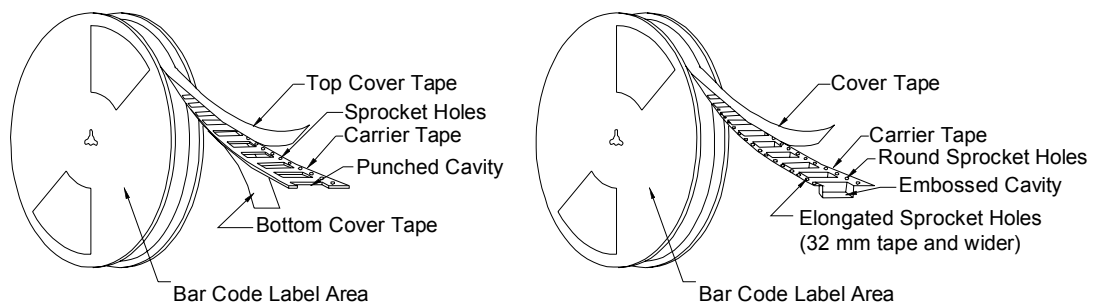

Figure 11 -- Bending radius for punched and embossed carrier

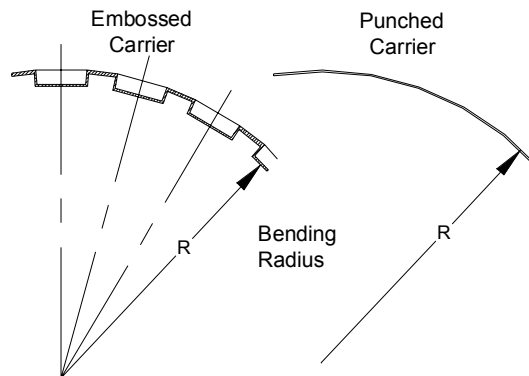
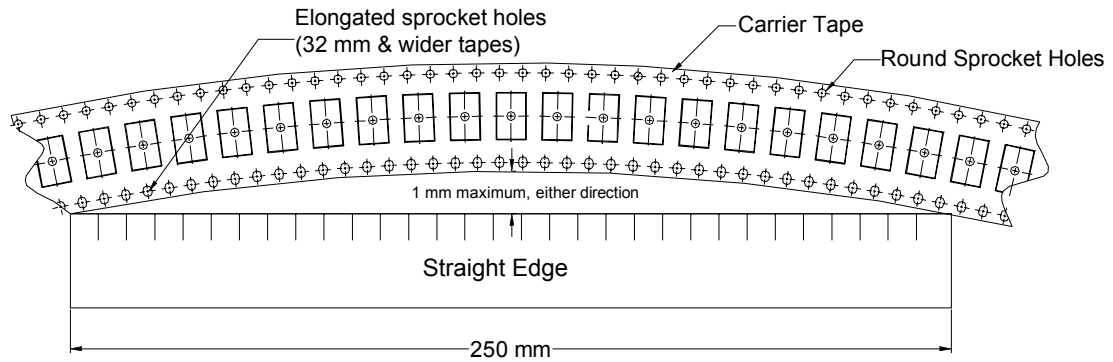

Figure 12 -- Maximum camber for punched and embossed carrier



To accurately measure camber, place the starting end of the carrier tape sample on the left end of the measurement fixture or straight edge. Moving to the right, measure the allowable camber at the highest point between where the left edge and the right edge of the carrier tape make contact with the measurement fixture or straight edge.

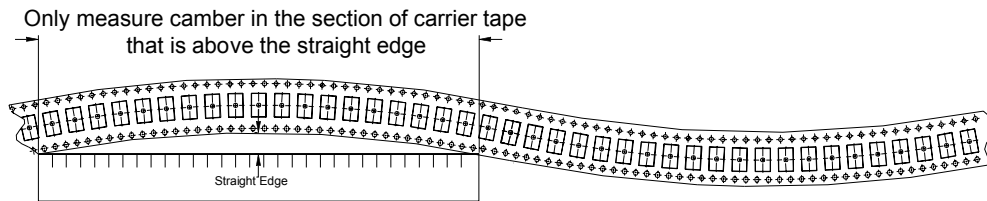
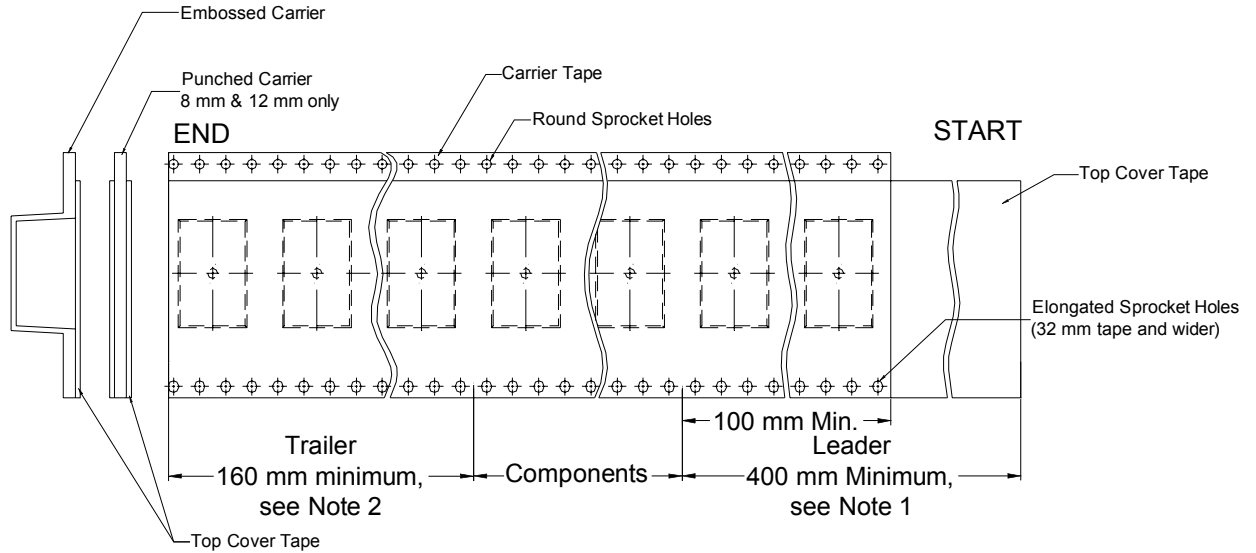

Figure 13 -- Tape leader & trailer dimensions for punched and embossed carrier

See section 4.0 for requirements (all dimensions in millimeters)



NOTES

1. There shall be a leader of 400 mm minimum of cover tape, which includes at least 100 mm of carrier tape with empty compartments and sealed by the cover tape. All of the leader may consist of the carrier tape with empty compartments sealed by cover tape.
2. There shall be a trailer of 160 mm minimum of empty carrier tape sealed with cover tape. The entire carrier tape must release from the reel hub as the last portion of the tape unwinds from the reel without damage to the carrier tape and the remaining components in the cavities.

Left intentionally blank.

Figure 14 -- Reel dimensions

See Section 4.0 for requirements (all dimensions in millimeters)

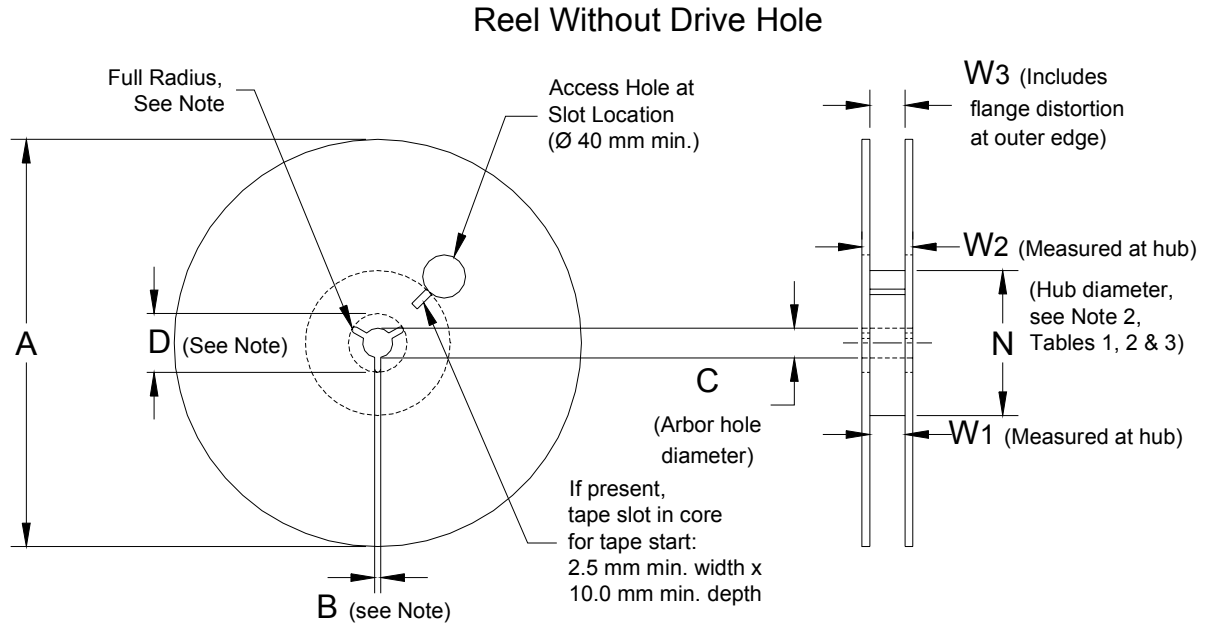

Note: Drive spokes optional; if used, dimensions B and D shall apply.

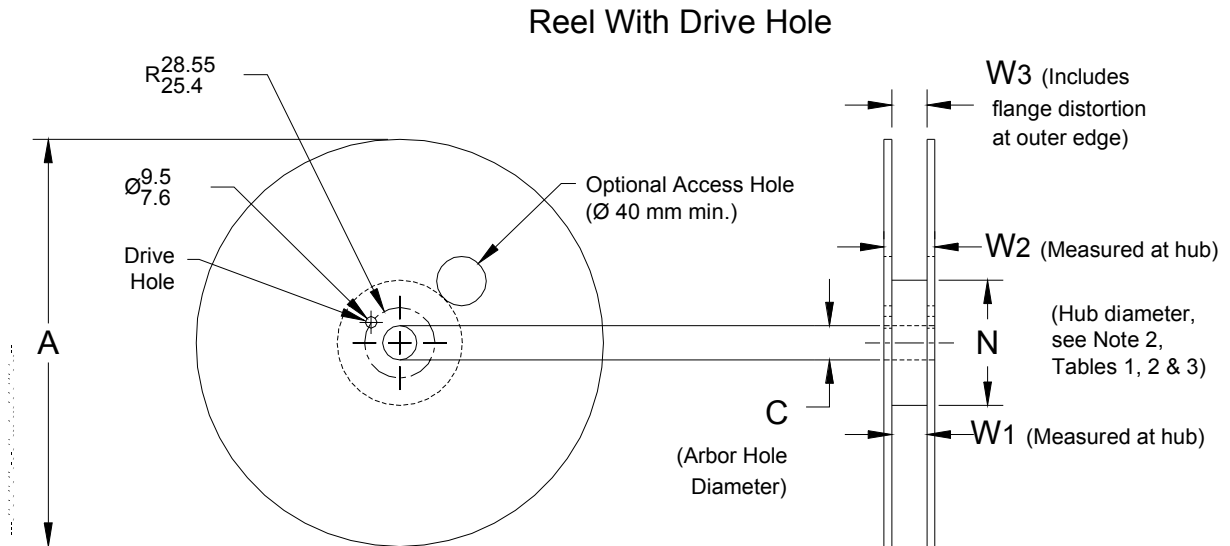

Table 4 -- Reel dimensions

See Section 4.0 for requirements (all dimensions in millimeters)

Constant Dimensions

Tape Size	A Max.	Reels Without Drive Hole			Reels With Drive Hole		
		B Min.	C	D Min.	B	C Max.	D
8 mm to 200 mm	609	1.5	13.0+0.5 -0.2	20.2	Not Applicable	29.2	Not Applicable

Variable Dimensions

Tape Size (mm)	N Min. See Note 2, Tables 1-3	W ₁	W ₂ Max for	W ₂ Max for	W ₃
			A < 360 mm See Note 1	A ≥ 360 and ≤ 609 mm See Note 2	
8	50	8.4 +1.5/-0.0	14.4	14.4	Shall Accommodate Tape Width Without Interference
12		12.4 +2.0/-0.0	18.4	18.4	
16		16.4 +2.0/-0.0	22.4	29.0	
24	60	24.4 +2.0/-0.0	30.4	37.0	
32	See Note 3	32.4 +2.0/-0.0	38.4	45.0	
44		44.4 +2.0/-0.0	50.4	57.0	
56		56.4 +2.0/-0.0	62.4	69.0	
72		72.4 Min.	89.0		
88		88.4 Min.	105.0		
104		104.4 Min.	121.0		
120		120.4 Min.	137.0		
136		136.4 Min.	153.0		
152		152.4 Min.	169.0		
168		168.4 Min.	185.0		
184	184.4 Min.	201.0			
200	200.4 Min.	217.0			

Notes

- For reels less than 360 mm diameter (A), the most widely used reel diameters are 178 mm ± 2 mm and 330 mm ± 2 mm. Reel diameters ranging from 254 mm to 292 mm also exist. Commonly used hub diameters are 80, 100, 150, and 178 mm.
- For reels greater than or equal to 360 mm diameter (A), various sizes exist with the most widely used being 381 mm ± 2 mm, 482 mm ± 2 mm and 558 mm ± 2 mm. Hub diameters vary widely, up to 254 mm.
- Tape with components must wrap around hub without damage.

Acknowledgements

The following team members contributed to the realization of the latest document revision:

James Adams – 3M
Mike Balbuena – Jabil Circuit, Inc.
Ted Eckerson – Jabil Circuit, Inc.
Albert Escusa – Texas Instruments.
Michael T. Farrell – 3M.
Gonzalo Herrera – Jabil Circuit, Inc.
Miguel A. Ojeda Sr. – Jabil Circuit, Inc.
Doug Romm – Texas Instruments.
Steven Kummerl – Texas Instruments.
Henry Sipes – Samtec, Inc.

The following team members are part of the Automated Component Handling Committee:

Bill Aldeen – Nu-Way Electronics
Teri Arguelles – Jabil Circuit, Inc.
Joe Biernacki – Stackpole
Ray Bloom – Advantek
Scott Carter – Tek Pak, Inc.
Ted Coler – Vishay
Michael Farrel – 3M
Bill Hall - Tayloreel
Gonzalo Herrera – Jabil Circuit, Inc.
Doug Laven – V-Tek, Inc.
Henry Sipes – Samtec, Inc.
Gabriela Szopa – Jabil Circuit, Inc.

Addendum

Complementary Taping Standards:

- EIA-726** **8 mm Punched & Embossed Carrier Taping of Surface Mount Components for Automatic Handling of Devices Smaller Than 2.0 mm x 1.2 mm**
- EIA-747** **Adhesive Backed Punched Plastic Carrier Taping of Singulated Bare Die and Other Surface Mount Components for Automatic Handling of Devices Generally Less Than 1.0 mm Thick**
- EIA-763** **Bare Die and Chip Scale Packages Taped in 8 mm & 12 mm Carrier Tape for Automatic Handling**

Other Reference Documents:

- ESD TR20.20** **ESD Association Standard – ESD Handbook**
- ESD ADV 1.0** **ESD Association Glossary – Glossary of Terms**
- SEMI E78** **Semiconductor Equipment and Materials International Standard— Electrostatic Compatibility – Guide to Assess and Control Electrostatic Discharge (ESD) and Electrostatic Attraction (ESA) for Equipment**

Recommendation:

For waste minimization purposes it is recommended that the industry modify its methods and equipment so that the minimum leader dimension can be eventually reduced from 400 mm to 320 mm and that the minimum trailer dimension be reduced from 160 mm to 80 mm.

EIA Document Improvement Proposal

If in the review or use of this document, a potential change is made evident for safety, health or technical reasons, please fill in the appropriate information below and mail or FAX to:

Electronic Components Association
Standards and Technology Department
2500 Wilson Blvd. – Suite 310
Arlington, VA 22201
FAX: (703-875-8908)

Document No.:	Document Title:
Submitter's Name:	Telephone No.: FAX No.: E-mail:
Address:	
Urgency of Change: Immediate: <input type="checkbox"/> At next revision: <input type="checkbox"/>	
Problem Area: a. Clause Number and /or Drawing: b. Recommended Changes: c. Reason/Rationale for Recommendation:	
Additional Remarks:	
Signature:	Date:
FOR EIA USE ONLY	
Responsible Committee:	
Chairman:	
Date comments forwarded to Committee Chairman:	

01715129



Electronic Components Association
2500 Wilson Boulevard, Suite 310 * Arlington, VA 22201 * tel 703-907-8021 * fax 703-875-8908
www.eaus.org